

CP2306-RGBe

Small-screen auditoriums | Boutique cinema | Screening rooms

Advanced, yet affordable, DCI compliant cinema projection with RGB laser illumination for screens up to 36 feet



Key features:

- › **Improved cinema experience** – expanded color gamut, greater brightness and contrast
- › **Future proofed** – HFR capable, 3D ready, compatible with 3rd-party IMBs and features AIC support
- › **Easy to operate** – adds UX inspired interface for playback, scheduling and content management
- › **Affordable performance** – eliminate lamp costs. Higher optical efficiency from laser diodes
- › **Enhanced Wavelength Diversity (EWD)** – suppresses visible speckle using both time and spatial decoherence.
- › **Long-lasting light source** – delivers stable light output and consistent colors for 30,000 hours



Integrated screen management system enabling seamless content and booth management with built-in automation controller

LAMPTOLASER.COM

Compare lamp and laser illumination technologies



Specifications

Christie CP2306-RGBe

Brightness	nominal	• Up to 6000 DCI lumens
	lifetime	• 30,000hrs to 70% brightness (<25°C ambient)
Contrast ratio		• 2000:1 full field on/off
Digital micromirror device		• 0.69" S2K 3-chip DMD DLP Cinema® • 2048 x 1080 pixels (2K)
Color gamut		• >90% of Rec 2020 coverage
Lens mount configuration		• Fully motorized intelligent lens system (ILS)
Lenses		• 1.2 - 1.72 1.33 - 2.1 1.62 - 2.7 2.09 - 3.9
Input line voltage		• Single phase 200-240V
Power Consumption		• 820W max
Laser class		• Class 1 – Risk Group 3
Automation		• GPIO/Health Connector with 4 opto-isolated GPI (inputs), 4 relay driven GPO (outputs), "Projector Health" status – relay driven output • "Serial-over-Ethernet" based automation
Weight		• As installed: 137lbs max (62kg)
Dimensions (w/o lens)	size (LxWxH)	• 27.4 x 27.1 x 15.9" (696 x 688 x 404mm)
Accessories		• Christie IMB-S3 ¹ • NAS-S2 4TB storage • NAS-S3 5.4TB storage • Rack mount stand

¹ Supports 3rd party IMB models from Dolby, GDC and others. Please contact Christie for updated compatibility list.

Front view

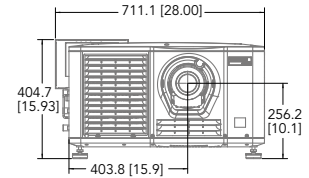

Side view

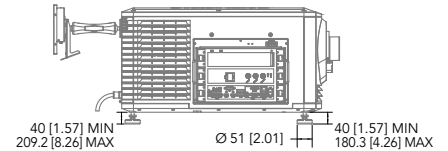

Top view

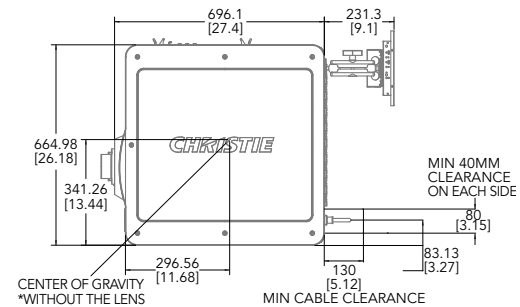

Side view

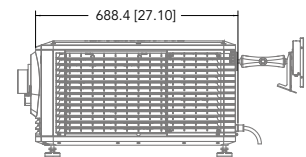

Corporate offices

Christie Digital Systems USA, Inc.
Cypress
PH: +1 714-236-8610

Christie Digital Systems Canada Inc.
Kitchener
PH: +1 519-744-8005

Worldwide offices

Australia PH: +61 (0) 7 3624 4888	Germany PH: +49 221 99 512-0	South Korea PH: +82 2 702 1601
Brazil PH: +55 11 3181-2952	India PH: +91 (080) 6708 9999	Spain PH: +34 (0) 91 633 99 90
China (Beijing) PH: +86 10 6561 0240	Mexico PH: +52 (55) 4744-1791	United Arab Emirates PH: +971 (0) 4 503 6800
China (Shanghai) PH: +(8621) 6030 0500	Singapore PH: +65 6877 8737	United Kingdom PH: +44 (0) 118 977 8000
Colombia PH: +57 (315) 652-9620		United States (Arizona) PH: +1 602-943-5700

For the most current specification information, please visit christiedigital.com

Copyright 2022 Christie Digital Systems USA, Inc. All rights reserved. Our centers of excellence for manufacturing in Kitchener, Ontario, Canada and in Shenzhen, China are ISO 9001:2015 Quality Management System-certified. All brand names and product names are trademarks, registered trademarks or tradenames of their respective holders. "Christie" is a trademark of Christie Digital Systems USA, Inc., registered in the United States of America and certain other countries. DLP® and the DLP logo are registered trademarks of Texas Instruments. Performance specifications are typical. Due to constant research, specifications are subject to change without notice.
CD2982_CINE0094-CP2306-RGBe-Datasheet-Oct-22-EN-US

